



INSTALLATION INSTRUCTIONS

Accessory

SPLASH GUARDS
P/N 08P00-TZ5-200

Application

2016 MDX

Publications No.

VERSION 1

Issue Date

JAN 2015

PARTS LIST

Left front splash guard

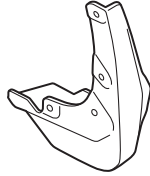

Right front splash guard

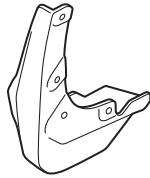

Left rear splash guard

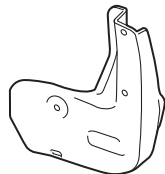

Right rear splash guard

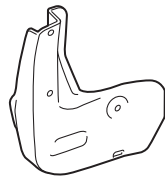

Left bracket (Marked L)

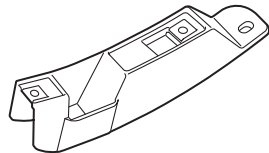

Right bracket (Marked R)

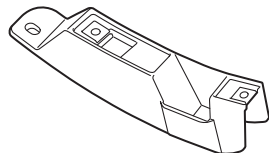

10 Self-tapping screws, 5 x 25 mm

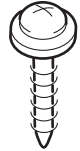

4 Self-tapping screws, 5 x 20 mm

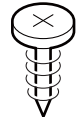

8 Spring nuts



TOOL AND SUPPLIES REQUIRED

Phillips screwdriver

Pushpin

Stubby Phillips screwdriver

High-quality paste wax

INSTALLATION

NOTE:

- Be careful not to damage the body paint finish.
- Clean and wax the areas to be covered with a high-quality paste wax.

Installing the Front Splash Guards

1. Turn the steering wheel fully counterclockwise.

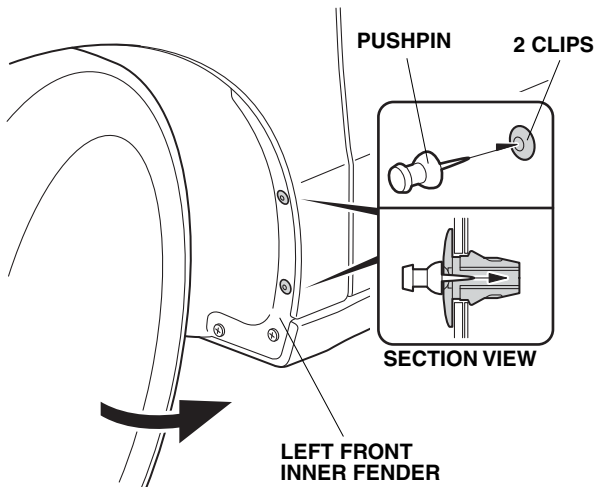

QBN0501AJ

2. Using a pushpin, pierce the center of the top two clips on the left front inner fender.
3. Remove the lower two self-tapping screws from the left front inner fender.

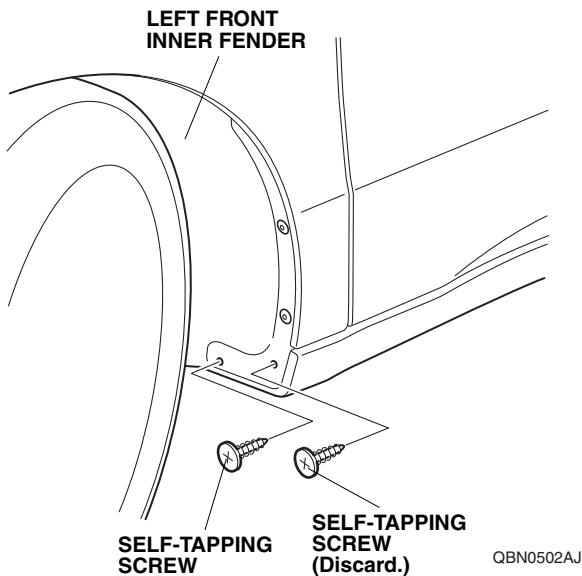

QBN0502AJ

4. Loosely secure the left front splash guard on the left front inner fender with three 5 x 25 mm self-tapping screws provided and one self-tapping screw removed in step 3.

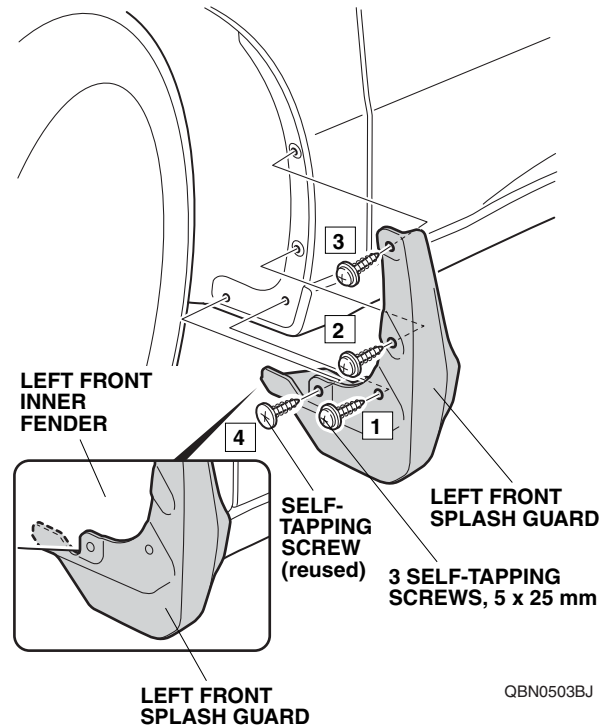

QBN0503BJ

5. While holding the left front splash guard against the left front inner fender, tighten the four self-tapping screws in the order shown.
NOTE: Make sure there is no gap between the left front splash guard and the vehicle body. If there is a gap, loosen the self-tapping screws, hold the splash guard against the body, and retighten the screws.
6. Turn the steering wheel fully clockwise, and repeat steps 2 through 5 to install the right front splash guard.

Installing the Rear Splash Guards

7. Remove the two self-tapping screws from the left rear inner fender.

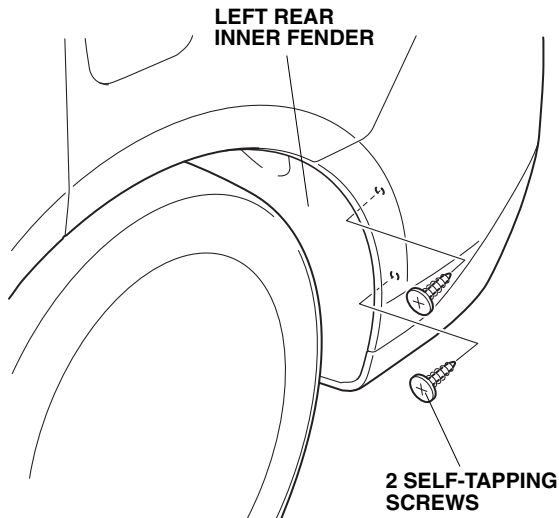

QBN0504AJ

8. Get the left bracket and install two spring nuts to the left bracket.

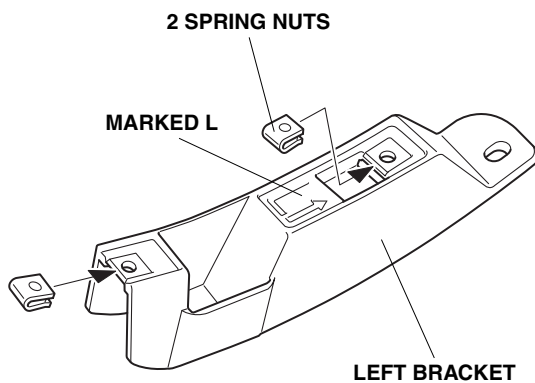

QBN0505AJ

9. Install the left bracket to the left rear inner fender using two 5 x 25 mm self-tapping screws.

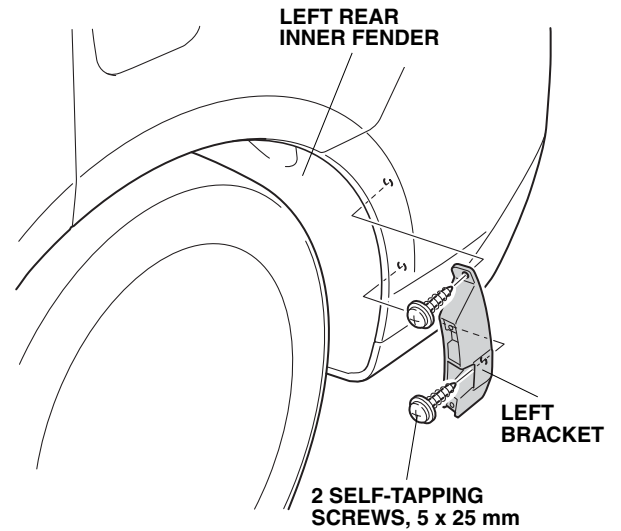

QBN0506AJ

10. Install one spring nut to the left rear splash guard in the area shown.

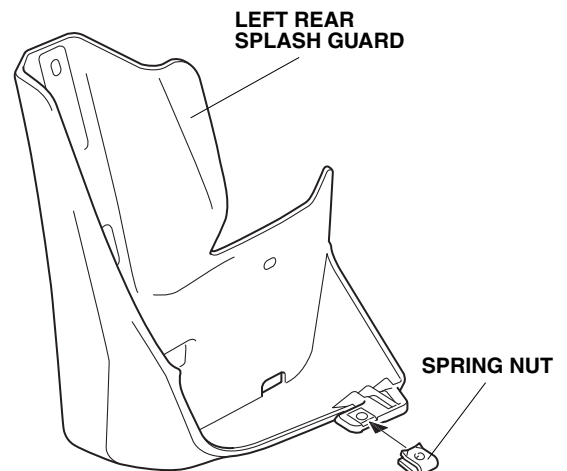

QBN0507AJ

11. Install one spring nut to the left rear inner fender through the hole shown.

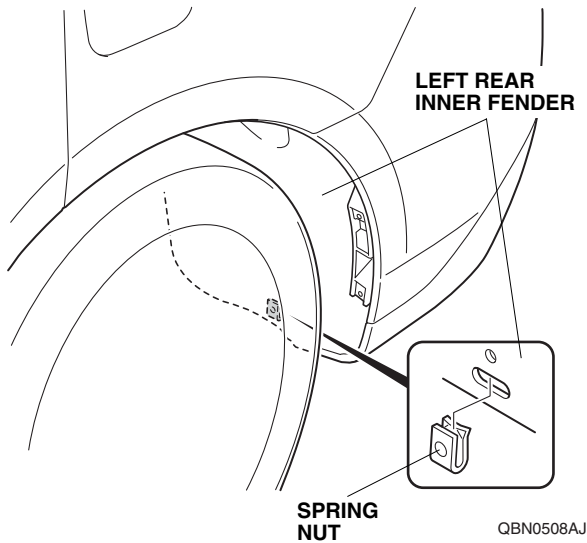

12. Loosely install the left rear splash guard to the left bracket and left rear inner fender with one 5 x 20 mm self-tapping screw provided and two self-tapping screws removed in step 7.

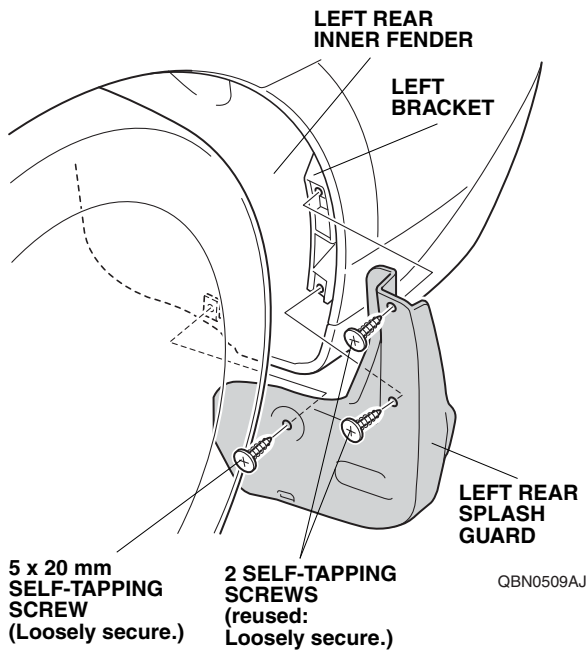

13. Loosely secure the left rear splash guard to the rear bumper with one additional 5 x 20 mm self-tapping screw provided.

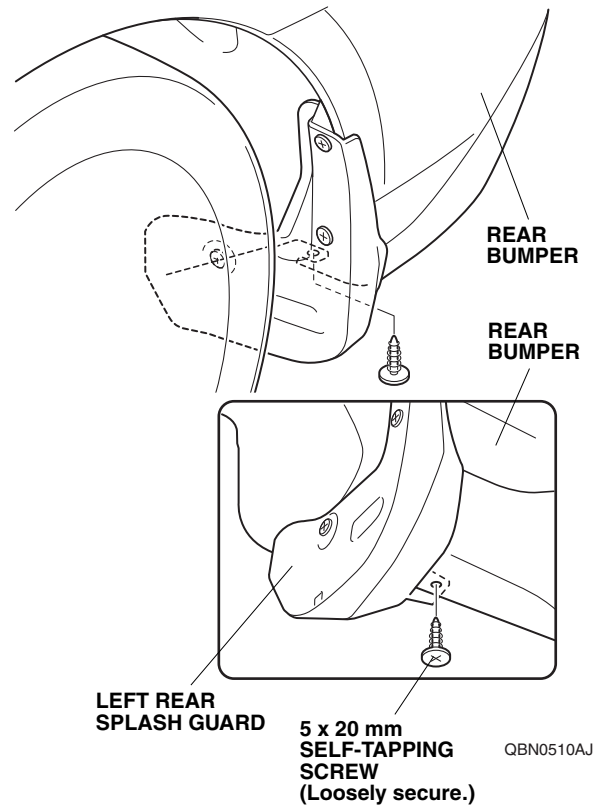

14. While holding the left rear splash guard against the rear bumper, tighten the four self-tapping screws in the order shown.

NOTE: Make sure there is no gap between the left rear splash guard and the vehicle body. If there is a gap, loosen the self-tapping screws, hold the splash guard against the body, and retighten the screws.

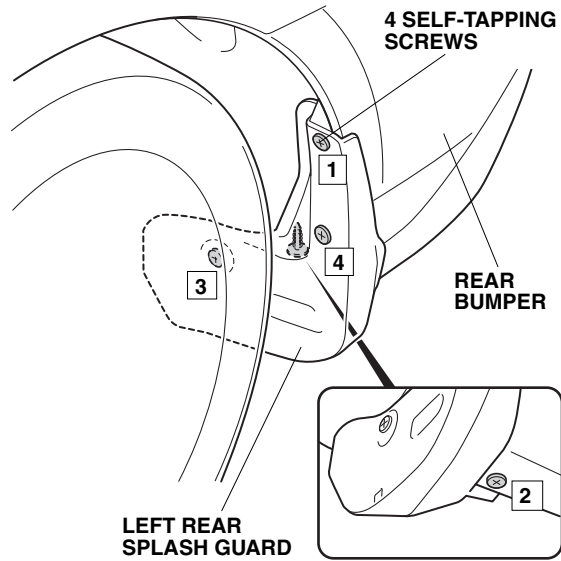

QBN0511AJ

15. Repeat steps 7 through 14 to install the right rear splash guard.